

Backflow Prevention Guidelines for Ag Chem Facilities That Fill Pesticide and Fertilizer Application Equipment

Backflow Prevention Devices

Minnesota Department of Agriculture (MDA) and Minnesota Department of Labor and Industry (MDLI) regulations require the use of a backflow prevention device or fixed air gap when filling fertilizer or pesticide application equipment from a municipal water supply, private well, or surface water. The backflow prevention device must comply with the MDLI regulations and the Minnesota Plumbing Code. Before installing any backflow prevention device, check with your local municipality or one of the regional MDLI plumbing inspectors for specifications. Requirements may vary for each municipality and each situation.

Listed below are four specific examples of backflow prevention systems that can be installed to prevent backflow when filling fertilizer or pesticide application equipment. Be aware that MDLI regulations may require proper backflow prevention when filling mobile water nurse tanks.

➤ Air gap

A physical separation from the discharge outlet to the rim of the tank, container, etc..

EXAMPLE: A firm uses a 3-inch water line to fill pesticide or fertilizer application equipment. The physical distance from the opening of the application equipment to the end of the water line must be two (2) times the diameter of the water line, or in this case, six (6) inches. The air gap distance must be maintained under all circumstances.

When filling application equipment, if an air gap cannot be maintained (fixed and permanent), then the firm must use an approved type of backflow device when filling application equipment. See example diagrams for specific installation guidelines.

➤ Reduced Pressure Principle Device (RPP or also referred to as RPZ)

An RPZ is made up of two independent check valves with an automatic pressure differential valve located between the two valves. If either check valve leaks, the relief valve will discharge to the atmosphere. If located properly, this device could be used by itself for prevention of backflow when filling application equipment.

➤ Pressurized Vacuum Breaker (PVB)*

The most common installation of a PVB would be at an elbow in a vertical position where it is readily accessible for periodic inspection and servicing. Due to the possibility of some spillage, do not locate these valves in concealed areas where spillage of water may cause damage.

If located properly, this device could be used by itself for prevention of backflow when filling application equipment. Installation must be in a continuous pressure system, at a minimum of 12 inches above overflow level of the equipment being filled. A shutoff valve must be installed downstream of the PVB (on the outlet side).

* When installing any RPP, RPZ or a PVB

These devices must be installed by a licensed plumber. A firm must notify the public water supplier within 30 days following installation of the device on a community public water system. A plumbing permit must be obtained from the administrative authority prior to installation. The backflow device must be tested upon initial installation and at least annually thereafter. All installations must be done by a licensed plumber who will comply with the 2015 Minnesota Plumbing Code Parts 603.5.23 through 603.5.23.4. Testing of backflow prevention devices requires certification to ASSE standard 5110. See MDLI's Backflow Devices Factsheet/2015 Minnesota Plumbing Code for additional requirements. Also see the following example diagrams for specific applications.

➤ Atmospheric Vacuum Breaker (AVB)

Atmospheric vacuum breakers must be installed utilizing good plumbing practices. This type of device can be used for protection when filling application equipment. Installation must be a minimum of 6 inches above overflow level of the equipment being filled. This device also must be installed where it is readily accessible. This device can not be under continuous pressure. Installation must be downstream from the last shutoff valve (no shutoff valve can be installed downstream from AVB). The most common installation location for an AVB (when filling agricultural application equipment) would be on the 90 degree angle of a boom type filling system. See example diagrams for specific application.

Definition

Backflow: The backward flow of water or other liquids, mixtures or substances (including agricultural chemicals) into a water supply from any source or sources.

Backsiphonage: A pressure drop or negative pressure from a vacuum (or partial vacuum) in the supply piping.

Fixed Air Gap System

A fixed air gap system is only used for filling application equipment. This system utilizes a physical separation from the discharge outlet to rim of the tank or container. To achieve an acceptable air gap allow a space of two times the inside diameter of the water supply line.

Example: For a 3-inch water supply line the minimum air gap which must be maintained would be 6 inches (2 X 3"). Air gap systems come in many shapes and sizes. Air gap systems can be constructed at a central filling location, or they can be constructed to be attached to the application tank being filled. An employee holding a hose above a tank while filling is not an adequate air gap since it is not fixed or permanent.

See examples 1(a), 1(b), 1(c), 1(d) and 1(e).

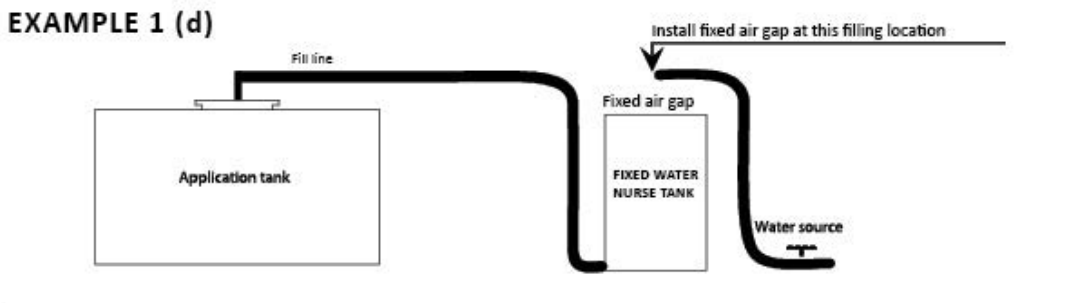
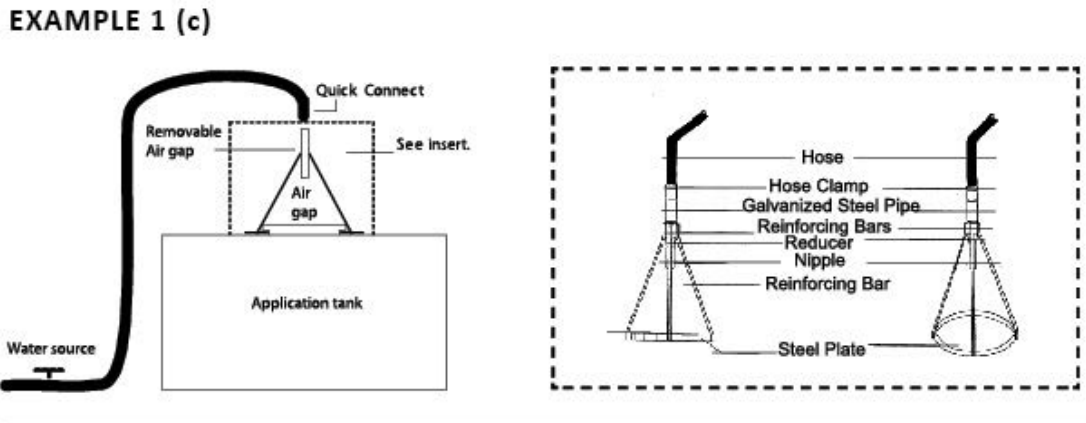
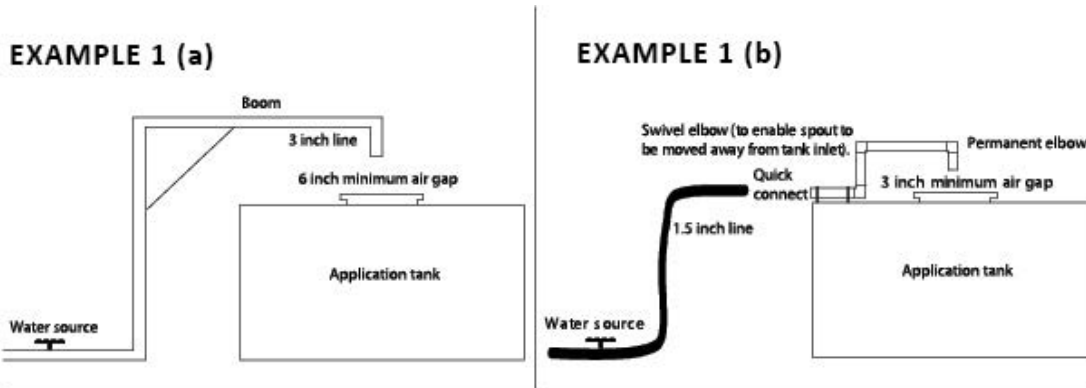

EXAMPLE 1 (e)

Proper backflow prevention is recommended to be installed and may be required by other state agencies when filling mobile water nurse tanks.

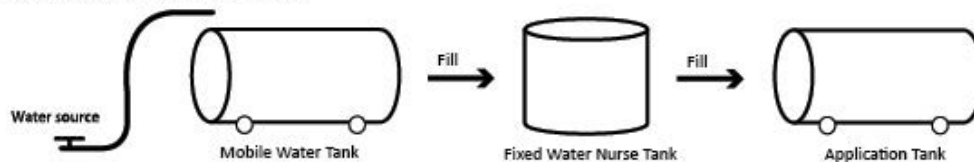

Backflow Prevention Devices

All installations for RPP, RPZ, and PVB must be done by a licensed plumber who will comply with the Minnesota Plumbing Code. These backflow devices must be tested upon initial installation and inspected at least annually thereafter by a licensed plumber. A test and inspection tag must be affixed to the device.

EXAMPLE 2(a): Reduced Pressure Principle Device

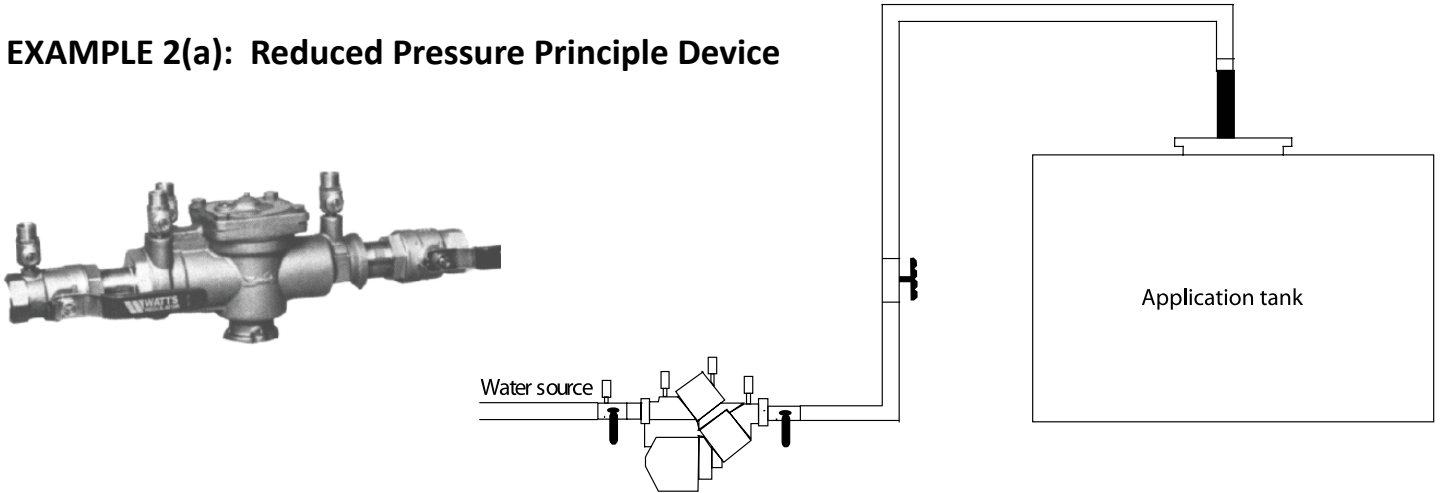

EXAMPLE 2(b): Pressurized Vacuum Breaker

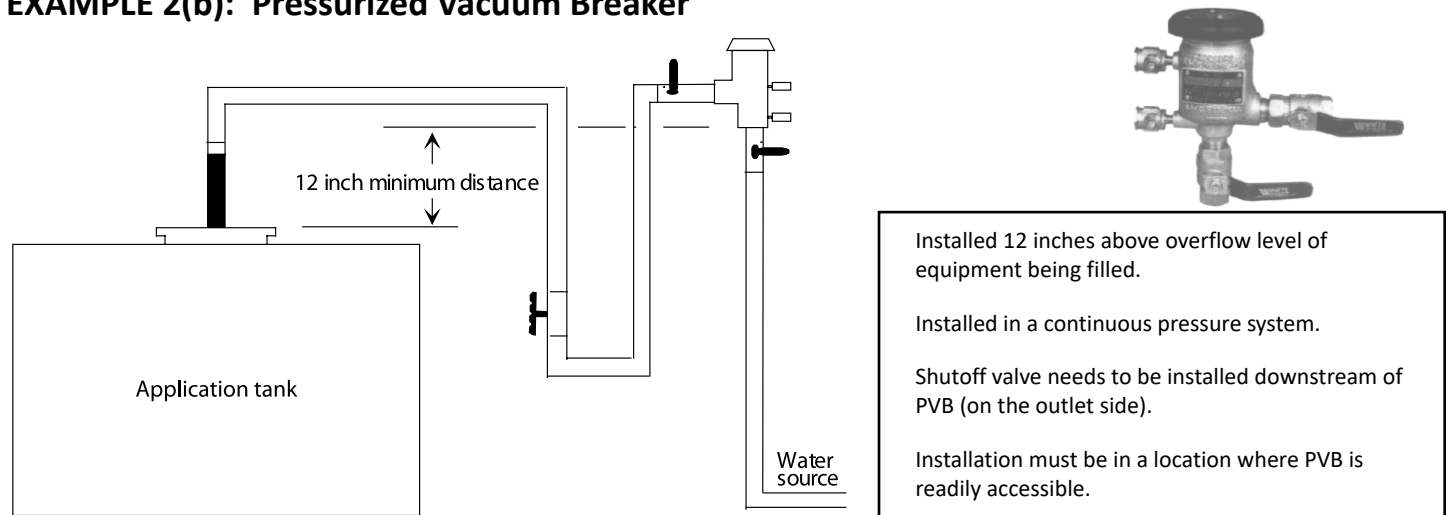

EXAMPLE of test and inspection tag affixed to the RPZ or PVB device.

**2015 Minnesota Plumbing Code
Part 603.5.23 through 603.5.23.4**

Installation of Testable Backflow Prevention Assembly

Notification of Installation
Testing and Maintenance
Inspection and Records
Notification of Removal

See **Minnesota Department of Labor and Industry Backflow Devices Factsheet/2015 Minnesota Plumbing Code**

www.dli.mn.gov/cld/pdf/fs_backflow.pdf

Reduced Pressure Zone Backflow Preventer - Accredited Testing By:

Company Name _____ Phone Number _____
 Address _____ City/State/Zip _____
 Bldg. Address _____ Manuf _____

	#1 CV psi/diff	Relief psi/diff	#2 CV	Tester Name & Number	Date
Installed					
1st Year					
2nd Year					
3rd Year					
4th Year					

EXAMPLE 2(c): Atmospheric Vacuum Breaker

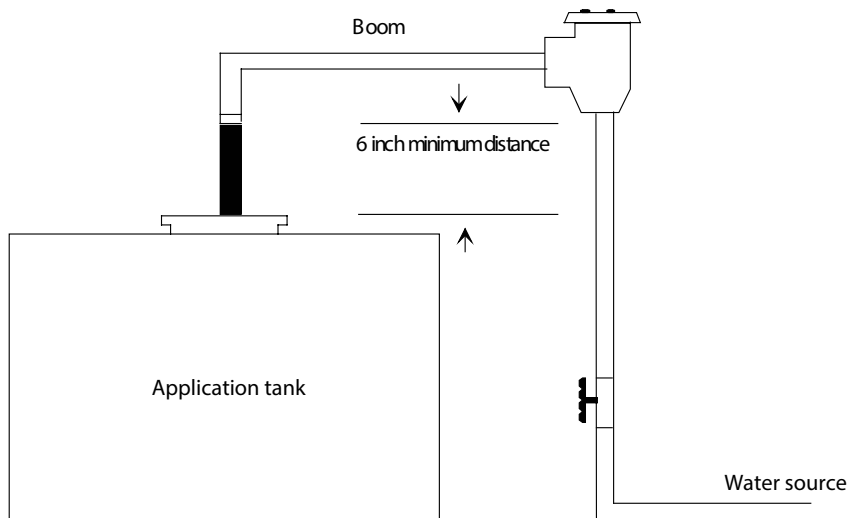

Installed 6 inches above overflow level of equipment being filled.

Must not be subject to continuous pressure.

Installed downstream of the shutoff valve (no shutoff valve downstream from AVB). Installation must be in a location where AVB is readily accessible.

Faucet Hose Connection Vacuum Breaker

Firms using an airgap system or atmospheric vacuum breaker device for backflow prevention when filling agrichemical application equipment should also install a hose connection vacuum breaker on the faucet (hose thread connection) for protection for other miscellaneous activities that may occur at their ag and non-ag chem facilities. A hose connection vacuum breaker would be required IF an unprotected faucet is being used to fill small hand sprayers.

Hose Connection Vacuum Breaker

ASSE Standard 1052 & ASSE Standard 1011 are two example of acceptable Hose connection vacuum breakers. Not rated for continuous pressure/ limited continuous pressure.



ASSE Standard 1011
Vacuum Breaker Hose Connection



ASSE Standard 1052
Vacuum Breaker Hose Connection

For Further Information Contact

Minnesota Dept. of Labor and Industry, 443 Lafayette Rd N, St. Paul, MN 55155, www.doli.state.mn.us/pe_contactus.html

Jim Peterson, Plumbing Program Supervisor - 651-284-5589

Please contact the plumbing inspector responsible for your part of the state.

Chuck Olson.....Central Region.....651-308-0786

John Roehl.....Southwest/Central Region.....320-247-9523

Mike Freiderich.....Southeast Region.....507-389-6507

Gary Topp.....Northwest Region.....218-739-1386

Brad Jensen.....Northeast Region.....218-733-7839